



Copyright © 2022 Nanjing Senasic Electronic Technology Co.,Ltd.

SNU301

Highly Integrated Universal Sensor Interface

SNU301 Datasheet

Version: V1.1

Date: 2022-11-17

Copyright © 2022 Nanjing Senasic Electronic Technology Co.,Ltd. All rights reserved.

No part of this document shall be excerpted, translated, reproduced, transmitted, or disseminated by any organization, company, or individual in any form or by any means without the prior written consent of Nanjing Senasic Electronic Technology Co.,Ltd.

Consultation Information

For further information on technical support, delivery and prices, please call the national consultation hotline: [021-5061-0206](tel:021-5061-0206), or you can obtain relevant support by email info@senasic.com.

Important Notice

 **捷捷** and other SENASIC icons are trademarks of Nanjing Senasic Electronic Technology Co.,Ltd. (former Ningbo SENASIC Electronic Technology Co., Ltd.abbreviated as SENASIC).

The purchased products, services and features are stipulated by the contract made between SENASIC and the customer. All or part of the products, services and features described in this document may not be within the purchase scope or the usage scope. Unless otherwise specified in the contract, all statements, information, and recommendations in this document are provided "AS IS" without warranties, guarantees or representations of any kind, either express or implied.

The content of this document may be changed due to product version upgrades, adjustments, or other reasons.Unless otherwise agreed, this document is used as Use guide only, all statements, information, and recommendations in this document do not constitute a warranty of any kind, express or implied.

目录

1	Introduction.....	6
2	Pin Description.....	7
2.1	Pin Configuration.....	7
2.2	Pin Description.....	7
3	Specification.....	8
3.1	Absolute Maximum Ratings.....	8
3.2	Operating Range.....	8
3.3	Pressure Sensor.....	8
3.4	Temperature Sensor.....	9
3.5	DAC Analog Output.....	9
3.6	Oscillator.....	9
3.7	Power On Reset.....	10
3.8	OTP Memory.....	10
3.9	Digital I/O Pins.....	10
4	Functional Description.....	11
4.1	Block Diagram.....	11
4.2	Analog front end.....	11
4.3	ADC.....	11
4.4	Temperature sensor.....	12
4.5	Analog output.....	13
4.6	SENT output.....	13
4.7	Power supply over voltage and reverse connection protection.....	13
5	Application Circuit.....	14
6	Package Dimension (mm).....	15
7	Revision History.....	16

List of Tables

Table 1	Order Information.....	6
Table 2	Pin Description.....	7
Table 3	Absolute Maximum Ratings.....	8
Table 4	Operating Range.....	8
Table 5	Pressure Sensor.....	8
Table 6	Temperature Sensor.....	9
Table 7	DAC Analog Output.....	9
Table 8	Oscillator.....	9
Table 9	Power On Reset.....	10
Table 10	OTP Memory.....	10
Table 11	Digital I/O Pins.....	10
Table 12	Pressure Data Rate.....	12
Table 13	Temperature Data Rate.....	13
Table 14	Revision History.....	16

List of Figures

Figure 1	Pin Configuration(Top View).....	7
Figure 2	Block Diagram.....	11
Figure 3	Pressure and Temperature Ratio Output.....	12
Figure 4	Application Circuit.....	14
Figure 5	Package Dimension.....	15

1 Introduction

SNU301 is a interface chip for temperature and air pressure sensor which can be applied in harsh automotive environment. The chip can drive the capacitive pressure sensor and then generate calibrated pressure data through the internal high resolution ADC, temperature compensation, and nonlinear calibration. The chip supports various output interface types, such as SENT, absolute analog voltage, and proportional analog voltage. The chip supports power supply over voltage and reverse connection protection, it operates over a wide temperature range of -40°C to 150°C.

1.1 Features

- Supply Voltage: 4.5V~5.5V
- OTP: 256Bytes
- Built-in high accuracy PGA
- Built-in two high-resolution 24-bit ADC
- Built-in temperature sensor
- Flexible output interface: absolute voltage, proportional voltage, and SENT
- Wide operation temperature range: -40°C to 150°C
- Support power supply over voltage and reverse connection protection from -20V to 20V
- Package: SSOP16
- Comply with RoHS directive, without hazardous substances
- Comply with AEC-Q100 Grade 0 standard



1.2 Applications

- Automotive pressure sensor
- Automotive pressure switch

1.3 Order Information

Table 1-1 Order Information

Model	Package	Ordering Number	Packing Option
SNU301	SSOP16	SNU301	Reel

2 Pin Description

2.1 Pin Configuration

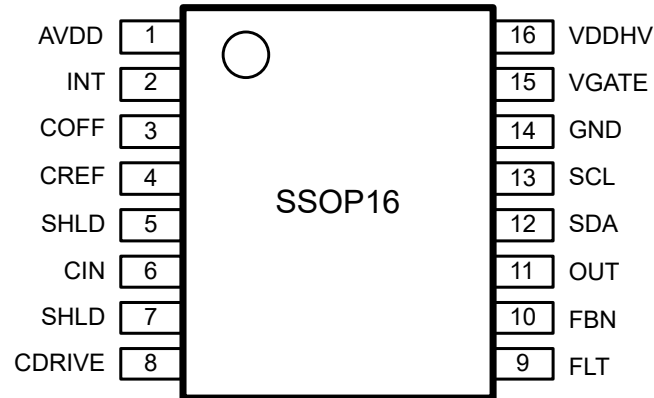

Figure 2-1 Pin Configuration(Top View)

2.2 Pin Description

Table 2-1 Pin Description

Pin No.	Name	Pin Type	Function
1	AVDD	Analog IO	Supply 5V from internal regulator
2	INT	Analog IO	Integral node output
3	COFF	Analog IO	Compensation capacitor output
4	CREF	Analog IO	Reference capacitor output
5	SHLD	Analog IO	Shielding output
6	CIN	Analog IO	Capacitive sensor input
7	SHLD	Analog IO	Shielding output
8	CDRIVE	Analog IO	Capacitive sensor driver output
9	FLT	Analog IO	Filter port output
10	FBN	Analog IO	Feedback input of DAC output buffer
11	OUT	Analog/Digital IO	Analog or digital output
12	SDA	Digital IO	I ² C data port
13	SCL	Digital IO	I ² C clock port
14	GND	Ground	Ground
15	VGATE	Analog IO	High-voltage power supply control port
16	VDDHV	Supply	Power supply

3 Specification

3.1 Absolute Maximum Ratings

Table 3-1 Absolute Maximum Ratings

Parameter	Symbol	Values			Unit	Note/Test Condition
		Min.	Typ.	Max.		
Supply Voltage	V _{DDHV1}	-20		20	V	VDDHV
	V _{GATE}	-0.3		20	V	VGATE
Analog Input Voltage	V _{io,ana1}	-0.3		AVDD+0.3	V	Pins: CIN, COFF, CDRIVE, GREF, INT, FLT, OUT, FBN
Operating Temperature	T _j	-40		150	°C	Normal mode
Storage Temperature	T _{storage}	-40		150	°C	Device not powered
ESD HBM	V _{ESD,HBM}	-2000		2000	V	All pins according to JS-001-2014
ESD CDM	V _{ESD,CDM}	-750		750	V	All pins according to JS-002-2014
Latch up	I _{LU}	-200		200	mA	All pins according to JEDEC 78D
Output Voltage	V _{OUT}	-0.3		AVDD+0.3	V	OWI, SENT, OUT
Output Current	I _{io,dig1}	-10		10	mA	Digital IO pins: SCL, SDA

3.2 Operating Range

Table 3-2 Operating Range

Parameter	Symbol	Values			Unit	Note/Test Condition
		Min.	Typ.	Max.		
Supply Voltage	V _{DDHV2}	4.5	5.0	5.5	V	Measurement of pressure and temperature
Supply Current	I _q	2	3	5	mA	No output load
Ambient Temperature	T _{operating}	-40		150	°C	Normal operation
	T _{otp}	-15		105	°C	Programming/erasing

3.3 Pressure Sensor

Table 3-3 Pressure Sensor

Parameter	Symbol	Values			Unit	Note/Test Condition
		Min.	Typ.	Max.		
Measurement Error ^[1]		-0.5%		+0.5%	Full scale	T _A = -40°C to 150°C
Pressure Measurement Stability Range	P _{sta}	-0.25%		+0.25%	Full scale	
Pressure Response Time ^[2]	T _p	10		50	ms	

[1] Above pressure error result is typical value and depends on sensor type.

[2] This result was measured with the INT capacitor set to 100nF, it may change with the configuration of the INT node capacitance setting.

3.4 Temperature Sensor

Table 3-4 Temperature Sensor

Parameter	Symbol	Values			Unit	Note/Test Condition
		Min.	Typ.	Max.		
Measurement Error	T_{Error}	-1		+1	°C	$T_A = -20^{\circ}\text{C}$ to 70°C $V_{DDHV} = 5\text{V}$
		-2		+2	°C	$T_A = -40^{\circ}\text{C}$ to 125°C $V_{DDHV} = 4.5$ to 5.5V
Temp Measurement Stability Range	T_{stab}	-0.5		+0.5	°C	Minimum 95% of the measurement range

3.5 DAC Analog Output

Table 3-5 DAC Analog Output

Parameter	Symbol	Values			Unit	Note/Test Condition
		Min.	Typ.	Max.		
DAC Resolution	R_{DAC}		12		bits	Minimum 95% of the measurement range
Output Current	I_{DACOUT}		-5		mA	Sink current, output range: 10% to 100% AVDD
			5		mA	Source current, output range: 0% to 90% AVDD
Output Short Current	I_{DACST}	-25		25	mA	Minimum 95% of the measurement range
Load Capacitance	C_{LDAC}	5	10	100	nF	Defined for best EMC performance
DNL	DNL_{DAC}	-1		1	LSB	$R_{DAC} = 12\text{bits}$
INL	INL_{DAC}	-2		2	LSB	$R_{DAC} = 12\text{bits}$ Best Fit
High Level Output Clamp Range	$R_{g_{clampH}}$	50		100	%	
Low Level Output Clamp Range	$R_{g_{clampL}}$	0		50	%	
Output Clamp Range Step	STP_{clamp}		16		LSB	$R_{DAC} = 12\text{bits}$

3.6 Oscillator

Table 3-6 Oscillator

Parameter	Symbol	Values			Unit	Note/Test Condition
		Min.	Typ.	Max.		
Frequency Range	F_{OSC}		9.8304		MHz	1MHz optional
Frequency Tolerance	$F_{osc,rg}$	-1%		+1%	Full scale	$T_A = 0^{\circ}\text{C}$ to 70°C
		-2%		+2%	Full scale	$T_A = -40^{\circ}\text{C}$ to 150°C

3.7 Power On Reset

Table 3-7 Power On Reset

Parameter	Symbol	Values			Unit	Note/Test Condition
		Min.	Typ.	Max.		
Power On Reset Level	V_{POR}		1.9		V	Measured at Pin AVDD
Power On Reset Release Level	V_{THR}		2.0		V	Measured at Pin AVDD
Power On Reset Time	t_{POR}			0.2	ms	

3.8 OTP Memory

Table 3-8 OTP Memory

Parameter	Symbol	Values			Unit	Note/Test Condition
		Min.	Typ.	Max.		
Program Temperature	T_{otp}		25		°C	
Program Supply Voltage	V_{wotp}	6.9	7	7.2	V	
OTP Memory Data Retention Time	t_{Retotp}	10			y	Defect rate < 1ppm over lifetime for typical mission temperature profile

3.9 Digital I/O Pins

Table 3-9 Digital I/O Pins

Parameter	Symbol	Values			Unit	Note/Test Condition
		Min.	Typ.	Max.		
Input Low Voltage	V_{IL}			$0.2 V_{AVDD}$	V	
Input High Voltage	V_{IH}	$0.8 V_{AVDD}$			V	
Output Low Voltage	V_{OL}			$0.2 V_{AVDD}$	V	$I_{OL}=4mA$
Output High Voltage	V_{OH}	$0.8 V_{AVDD}$			V	$I_{OL}=4mA$
Digital Pin Output Current	$I_{out,DIG}$	-4		4	mA	
Digital Pin Input Capacitance	$C_{in,DIG}$			10	pF	

4 Functional Description

SNU301 is a interface chip for temperature and air pressure sensor. The chip can drive the capacitive pressure sensor and then generate calibrated pressure data. Two high resolution sigma-delta ADCs are applied to evaluate analog input signals such as temperature, air pressure, power voltage. An DSP cell is applied to perform calibration according to sensor's feature. On-chip memory is integrated to store customer's specific configuration, the unique ID of chip and calibration data. You can easily choose different kinds of output interface types such as SENT, absolute voltage, proportional voltage.

4.1 Block Diagram

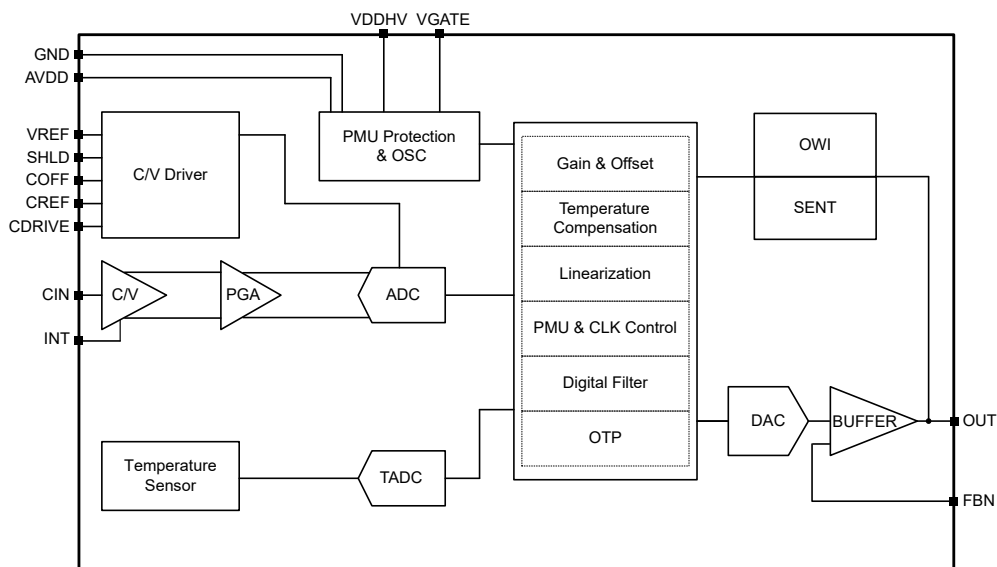

Figure 4-1 Block Diagram

4.2 Analog front end

The capacitor to voltage converter front end can sense capacitance variation of sensor and convert into analog voltage signal. The gain and offset of converter can be calibrate base on sensor feature and keep analog signal match the ADC input signal range.

4.3 ADC

- A high-resolution ADC performs analog-to-digital conversion of the analog pressure signal.
- A high-resolution TADC performs temperature measurement and assists in temperature compensation of the pressure signal.

Figure 4-2 Pressure and Temperature Ratio Output

The output of the ADC is digitally filtered with 24-bit resolution. The reference voltage of the ADC is AVDD, which automatically follows the VDDHV voltage when the VDDHV voltage is in the range of 4.5V to 5.5V. The final analog pressure signal is normalized to the ratio of the AVDD voltage and output through the OUT port. The bandwidth and Output Data Rate (ODR) of the digital filter can be set by 'ODR_P'. ODR can be set from 5Hz to 75Hz.

Table 4-1 Pressure Data Rate

ORD_P	Pressure data rate	Description
0	Reserved	
1	Reserved	
2	Reserved	
3	Reserved	
4	Reserved	
5	Reserved	
6	75Hz	
7	37.5Hz	
8	20Hz	notch filter option, configuration with 60Hz notch
9	20Hz	notch filter option, configuration with 60Hz notch
10	10Hz	notch filter option, configuration with 60Hz notch
11	10Hz	notch filter option, configuration with 60Hz notch
12	5Hz	notch filter option, configuration with 60Hz notch
13	5Hz	notch filter option, configuration with 60Hz notch
14,15	Reserved	

4.4 Temperature sensor

The temperature measurement channel measures the working temperature of the sensor and performs temperature compensation on the sensor signal. This channel works independently of the pressure channel. The output of the temperature sensor is digitized by a 24-bit ADC (TADC) and digitally filtered. The ODR setting of the temperature measurement channel is the same as the pressure signal channel, set by ODR_T. The temperature data can be read from TDATA register and output via the SENT interface.

The internal temperature sensor is factory calibrated, with its calibration coefficients stored in OTP, the chip can provide a temperature reading in degree Celsius, in the format of

$$T = \frac{\text{TDATA}}{2^{23}} \times A + B$$

A and B are temperature calibration coefficients.

Table 4-2 Temperature Data Rate

ORD_T	Temperature data rate
0	Reserved
1	Reserved
2	1.2kHz
3	600Hz
4	300Hz
5	150Hz
6	75Hz
7	37.5Hz
8,9	20Hz
10,11	10Hz
12,13	5Hz
14,15	Reserved

4.5 Analog output

The analog output port is used to output an analog signal representing pressure. The analog interface automatically cooperates with the OWI communication window after power-on, and the analog output is high impedance during the window period.

4.6 SENT output

The device output result at pin OUT with SENT protocol frame, it supports SAE J2716.

The chip uses fast and serial message channels and supports pause pulses to create SENT transfers with a constant number of clock ticks.

The SENT interface supports the OWI communication window after power-on. In the communication window, the communication can be calibrated through the OWI command sequence.

4.7 Power supply over voltage and reverse connection protection

The power management block can protect the chip within the range of $\pm 20V$ of chip power supply and avoid damage.

5 Application Circuit

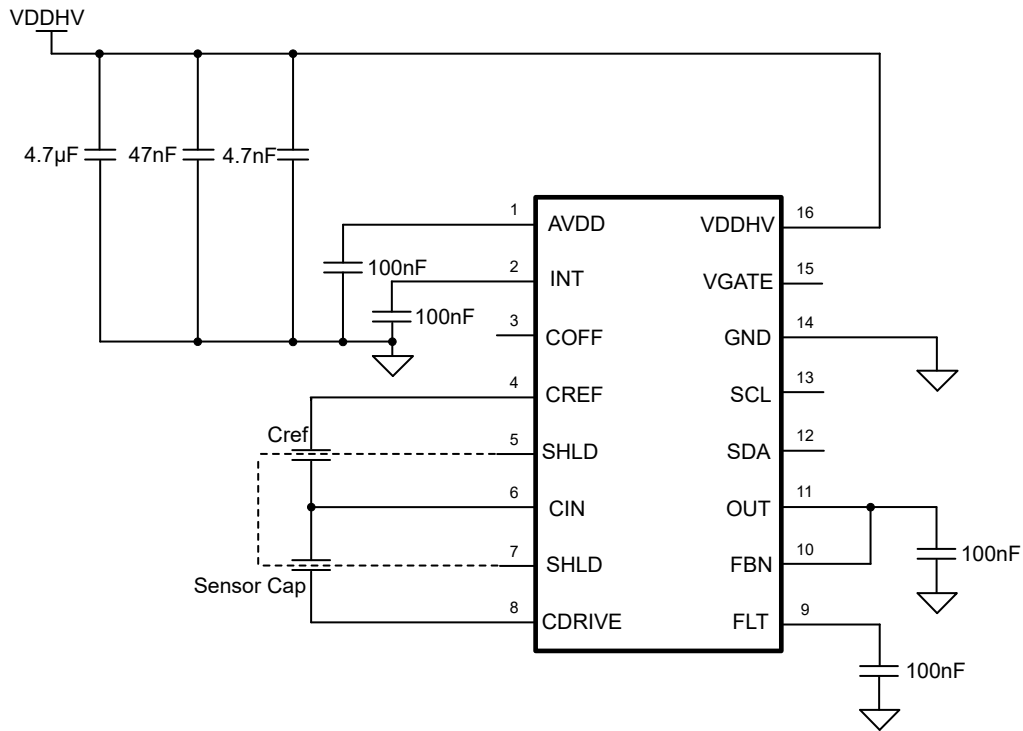
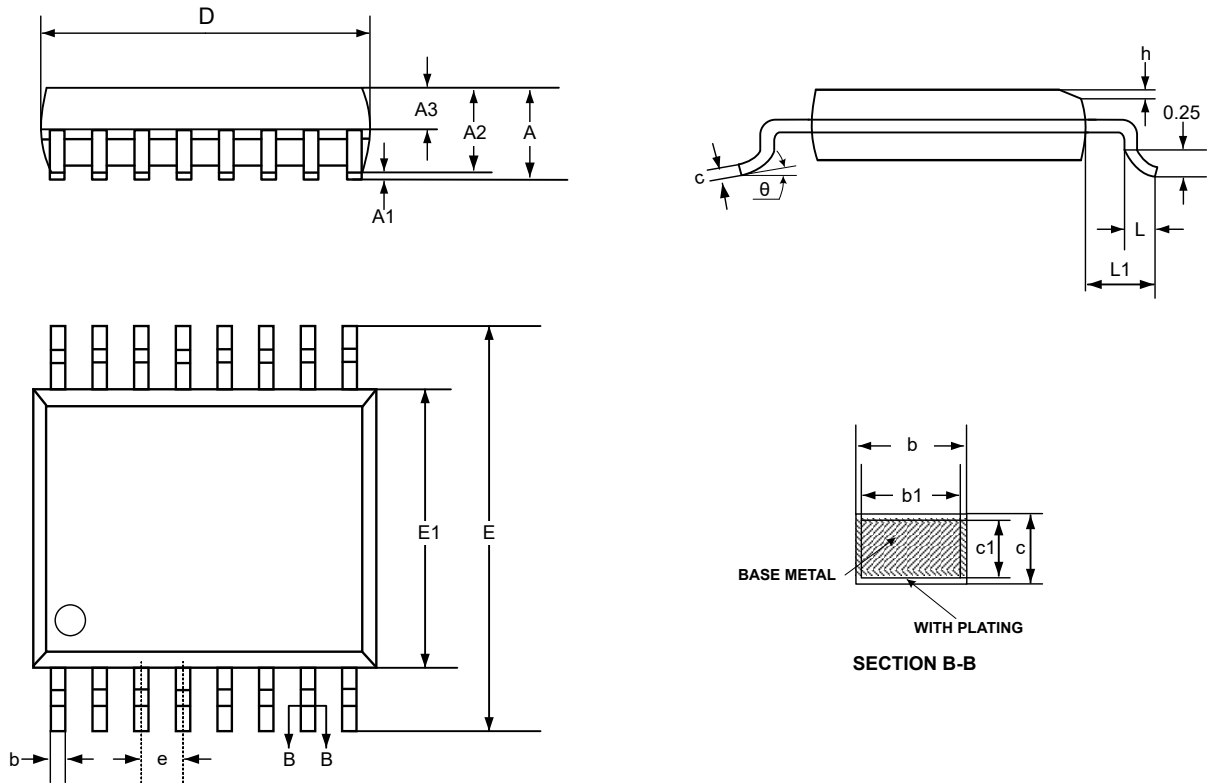

Figure 5-1 Application Circuit

6 Package Dimension (mm)



Symbol	Dimensions in Millimeters		
	Min	Nominal	Max
A			1.75
A1	0.10		0.225
A2	1.30	1.40	1.50
A3	0.60	0.65	0.70
b	0.23		0.31
b1	0.22	0.25	0.28
c	0.20		0.24
c1	0.19	0.20	0.21
D	4.80	4.90	5.00
E	5.80	6.00	6.20
E1	3.80	3.90	4.00
e	0.635 BSC		
h	0.25		0.5
L	0.5	0.65	0.80
L1	1.05 REF		
θ	0°		8°

Figure 6-1 Package Dimension

7 Revision History

Table 7-1 Revision History

Version	Date	Note
V1.0	2022.04.15	Initial version
V1.1	2022.11.17	1.Update Features and some descriptions. 2.Update Figure 5-1 Application Circuit and Figure 6-1 Package Dimension.