

SNE2402 Automotive 150-mA, High-Voltage, Ultra-Low-IQ Low-Dropout Regulator

Features

- AEC-Q100 qualified for automotive applications:
 - Temperature grade 0: $-40^{\circ}\text{C} \leq T_A \leq 150^{\circ}\text{C}$
- Extended junction temperature range:
 - Grade 0: $-40^{\circ}\text{C} \leq T_J \leq 165^{\circ}\text{C}$
- Low quiescent current I_Q :
 - 300nA typical shutdown I_Q
 - 3.5 μA typical at light loads
- 3V to 40V wide V_{IN} input voltage range with up to 42V transient
- Maximum output current: 150mA
- Output-voltage accuracy: 2%
- Typ. dropout voltage: 250mV@150mA load current for fixed 5V output version
- Stable with low-ESR (0.001 Ω to 1 Ω) ceramic output-stability capacitor (2.2 μF to 200 μF)
- Fixed 2.5V, 3.3V, and 5V output voltage

Typical Application

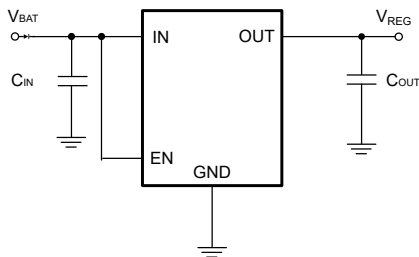

Typical Application Circuit

General Description

In automotive battery-connected applications, low quiescent current (I_Q) is important to save power and extend battery lifetime. Ultra-low I_Q must be included for always-on systems.

The SNE2402 is a low-dropout linear regulator designed to operate with a wide input-voltage range from 3V to 40V (45V load dump protection). Operation down to 3V allows the SNE2402 to continue operating during cold-crank and start and stop conditions. With only 3.5 μA typical quiescent current at light load, this device is an optimal solution for powering microcontrollers (MCUs) and CAN/LIN transceivers in standby systems.

The device features integrated short-circuit and overcurrent protection. Additionally, this device uses a thermally conductive package to enable sustained operation despite significant dissipation across the device. Because of these features, the device is designed as a power supply for various automotive applications.

Applications

- Automotive head units
- Telematics control units
- Headlights
- Body control modules
- Inverter and motor controls

Contents

1	Pin Description	3
2	Specifications	4
2.1	Absolute Maximum Ratings.....	4
2.2	ESD Ratings.....	4
2.3	Recommended Operating Range.....	4
2.4	Thermal Information.....	5
2.5	Electrical Characteristics: Grade 0 Options.....	5
3	Performance Characteristics	6
4	Detail Description	8
5	Package Outline	10
6	Revision History	16

1 Pin Description

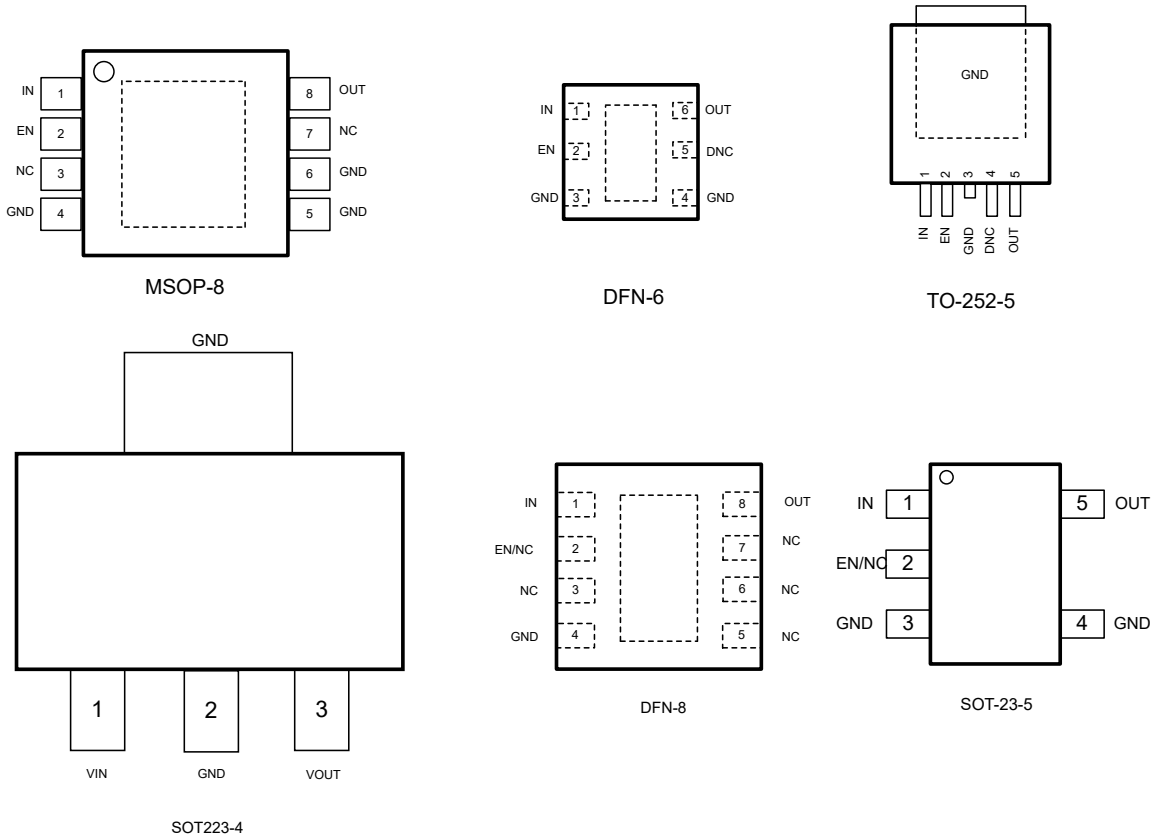

Pin						Name	Function
MSOP-8	DFN-6	TO-252-5	SOT223-4	DFN-8	SOT-23-5		
	5	4				DNC	Do not connect to a biased voltage. Tie this pin to ground or leave floating.
2	2	2		2		EN	Enable input pin
4/5/6	3/4	3	2	4	3/4	GND	Ground.
1	1	1	1	1	1	IN	Input power-supply pin
3/7				3/5/6/7	2	NC	Not Connected.
8	6	5	3	8	5	OUT	Regulated output voltage pin
Thermal pad							Connect the thermal pad to a large-area GND plane for improved thermal performance.

2 Specifications

2.1 Absolute Maximum Ratings

Over operating ambient temperature range (unless otherwise noted) ^{[1][2]}.

Parameter	Symbol	Rating	Unit
VIN to GND ^[3]	V_{IN}	-0.3 ~ 42	V
EN to GND ^[3]	V_{EN}	-0.3 ~ V_{IN}	V
OUT to GND	V_{OUT}	-0.3 ~ 7	V
Junction Temperature (grade 0)	T_J	-40 ~ 165	°C
Storage Temperature Range	T_{STG}	-40 ~ 150	°C

Note:

[1] Stresses greater than those listed under "Absolute Maximum Ratings" may cause permanent damage to the device. These are stress ratings only, and functional operation of the device at these or any other conditions beyond those indicated under "Recommended Operating Conditions" is not implied. Exposure to "Absolute Maximum Ratings" for extended periods may affect device reliability;

[2] All voltage values are with respect to GND;

[3] Absolute maximum voltage, withstand 45V for 200ms.

2.2 ESD Ratings

Parameter	Symbol		Value	Unit	
Electrostatic discharge	V_{ESD}	Human-body model (HBM), per AEC Q100-002 HBM ESD classification level H2	±2000	V	
		Charged-device model (CDM), per AEC Q100-011 CDM ESD classification level C3B	Corner pins (1, 4, 5, and 8)		±750
			Other pins		±500

2.3 Recommended Operating Range

Over operating ambient temperature range (unless otherwise noted).

Parameter	Symbol	Value	Unit
Unregulated input	V_{in}	3~40	V
Enable input	V_{EN}	0~ V_{in}	V
Output capacitor requirements ^[1]	C_{OUT}	2.2~200	μF
Output capacitor ESR requirements ^[2]	ESR	0.001~1	Ω
Ambient temperature (grade 0)	T_A	-40~150	°C
Junction temperature (grade 0)	T_J	-40~165	°C

Note:

[1] The output capacitance range specified in the table is the effective value;

[2] Relevant equivalent series resistance (ESR) value at $f = 10$ kHz.

2.4 Thermal Information

Thermal Metric	Symbol	MSOP-8	DFN-6	TO-252-5	DFN-8	UNIT
Junction-to-ambient thermal resistance	$R_{\theta JA}$	63.9	72.8	31.1	52.6	°C/W
Junction-to-case (top) thermal resistance	$R_{\theta JC(top)}$	50.2	85.8	39.9	66.2	°C/W
Junction-to-board thermal resistance	$R_{\theta JB}$	22.6	37.4	9.9	16.7	°C/W
Junction-to-top characterization parameter	ψ_{JT}	1.8	2.7	4.2	1.9	°C/W
Junction-to-board characterization parameter	ψ_{JB}	22.3	37.3	9.9	16.7	°C/W
Junction-to-case (bottom) thermal resistance	$R_{\theta JC(bot)}$	12.1	13.8	2.8	11.1	°C/W

2.5 Electrical Characteristics: Grade 0 Options

V_{IN} = 14V, 10 μ F ceramic output capacitor, grade 0 options (PWP package), T_J = -40°C to +150°C, over operating ambient temperature range (unless otherwise noted).

Parameter	Symbol	Conditions	Min	Typ	Max	Unit	
SUPPLY VOLTAGE AND CURRENT (IN)							
Input Voltage	V_{IN}		$V_{OUT(NOM)} + V_{(Dropout)}$		40	V	
Shutdown current	I_{SD}	EN = 0 V		0.3	1	μ A	
Quiescent current	I_Q	V_{IN} = 6 to 40 V, EN \geq 2 V, I_{OUT} = 0 mA		3.5	6	μ A	
		V_{IN} = 6 to 40 V, EN \geq 2 V, I_{OUT} = 0.2 mA		5	7	μ A	
V_{IN} undervoltage detection	$V_{(IN, UVLO)}$	Ramp V_{IN} down until the output turns OFF		2.45	2.85	V	
		Hysteresis		100		mV	
ENABLE INPUT (EN)							
Logic-input low level	V_{IL}				0.7	V	
Logic-input high level	V_{IH}		2			V	
REGULATED OUTPUT (OUT)							
Regulated output	V_{OUT}	$V_{IN} = V_{OUT} + V_{(Dropout)}$ to 14 V, I_{OUT} = 1 mA to 300 mA	-2%		2%		
Line regulation	$V_{(Line-Reg)}$	V_{IN} = 6 V to 40 V, I_{OUT} = 10 mA		5	10	mV	
Load regulation	$V_{(Load-Reg)}$	V_{IN} = 14 V, I_{OUT} = 1 mA to 300 mA			20	mV	
Dropout voltage	$V_{(Dropout)}$	$V_{OUT(NOM)} = 5$ V	$I_{OUT} = 150$ mA		250	350	mV
			$I_{OUT} = 100$ mA		165	220	mV
		$V_{OUT} = 3.3$ V	$I_{OUT} = 150$ mA		320	440	mV
			$I_{OUT} = 100$ mA		180	290	mV
Output current	I_{OUT}	V_{OUT} in regulation	0		150	mA	
Output current limit	$I_{(CL)}$	V_{OUT} short to 90% $\times V_{OUT}$		286		mA	
Power-supply ripple rejection	PSRR	$V_{(Ripple)} = 0.5$ VPP, $I_{OUT} = 1$ mA, frequency = 100 Hz, $C_{OUT} = 10$ μ F		90		dB	
OPERATING TEMPERATURE RANGE							
Junction shutdown temperature	$T_{(SD)}$			185		°C	
Hysteresis of thermal shutdown	$T_{(HYST)}$			20		°C	

3 Performance Characteristics

$V_{IN}=14V$, $V_{OUT}=5V$, $C_{IN}=2.2\mu F$, $C_{OUT}=10\mu F$, $T_A=-40\sim 150^{\circ}C$, unless otherwise noted.

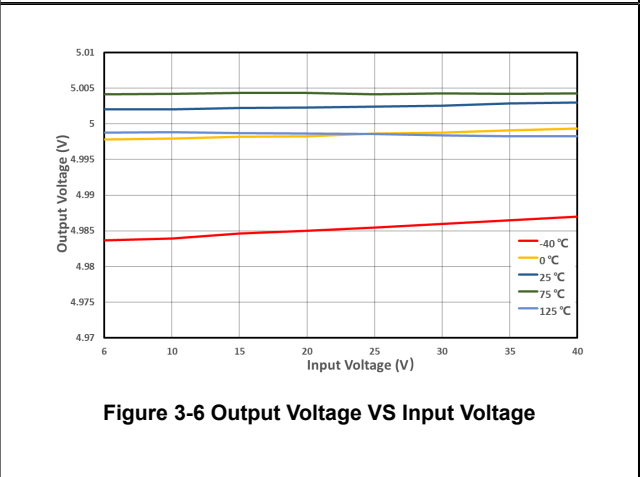
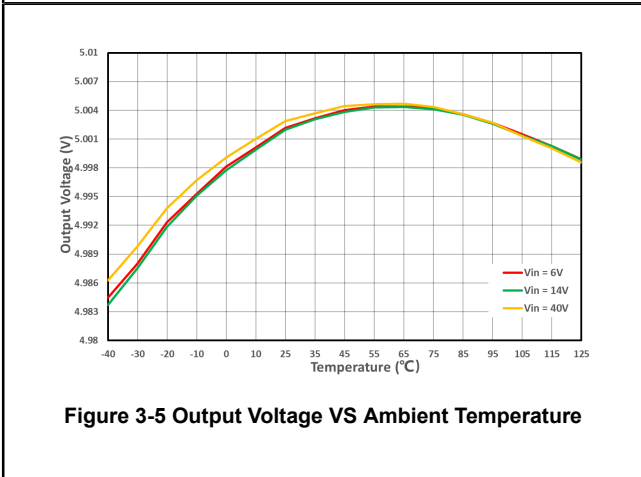
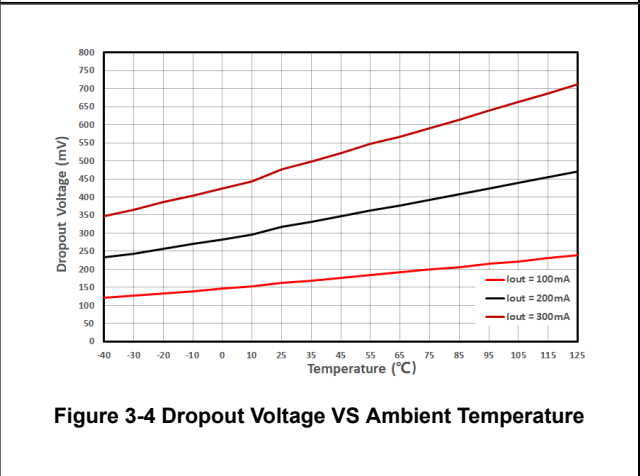
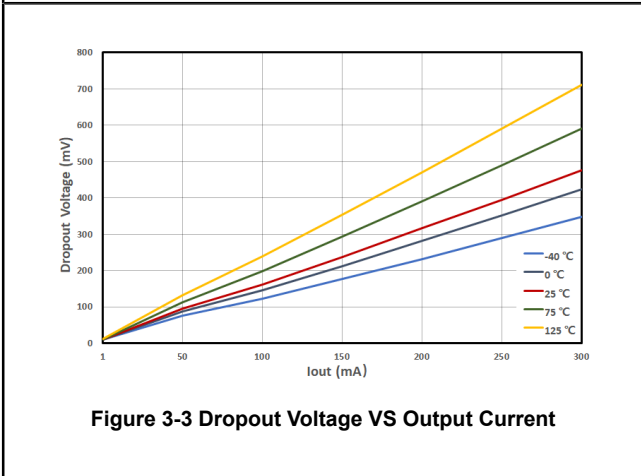
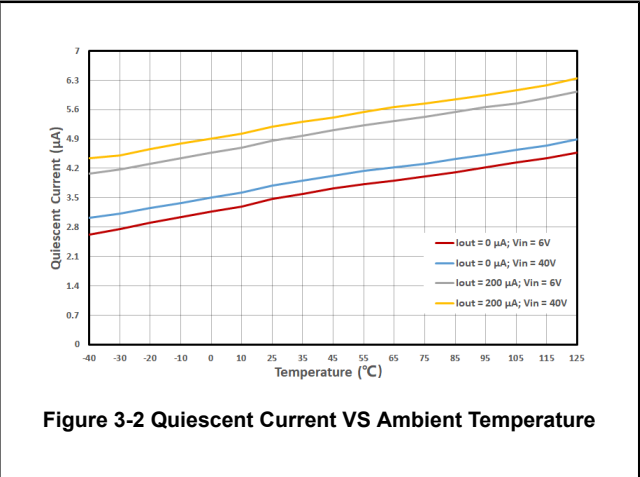
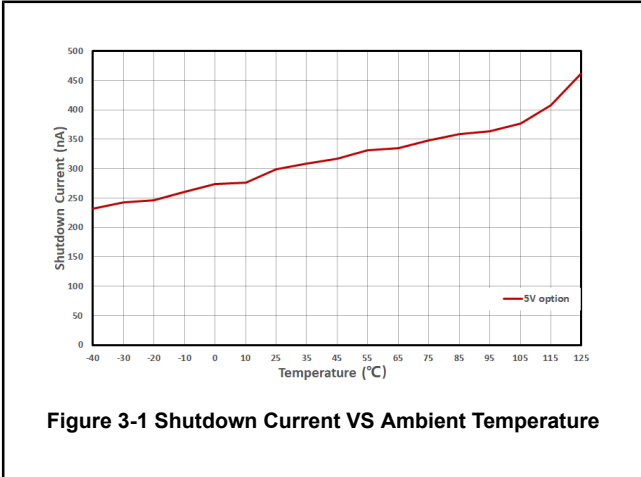

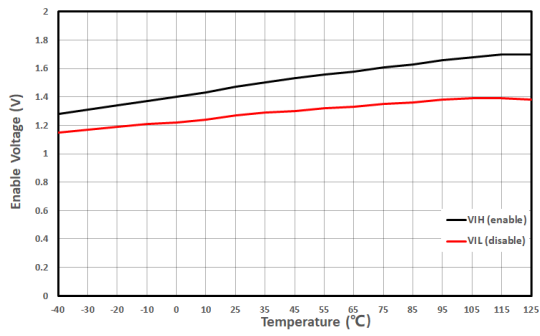

Figure 3-7 Enable Voltage VS Ambient Temperature

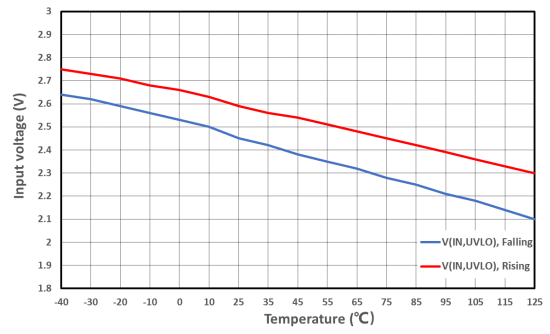

Figure 3-8 UVLO VS Ambient Temperature

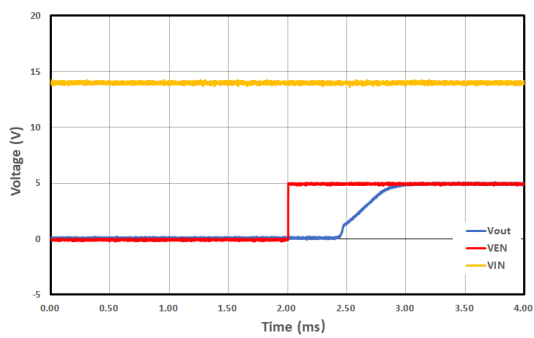

Figure 3-9 Startup with Enable

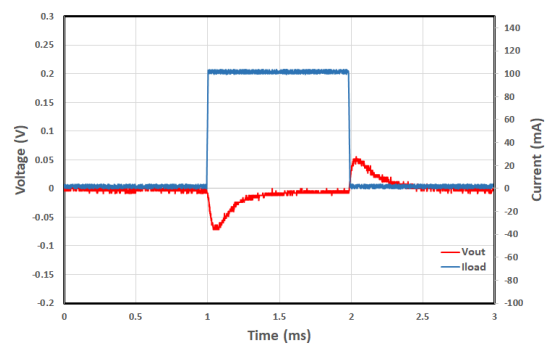

Figure 3-10 Load Transient

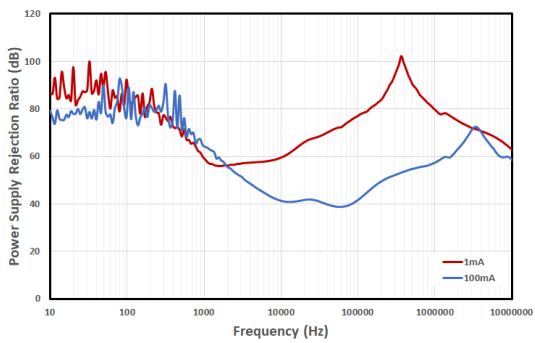

Figure 3-11 PSRR VS Frequency

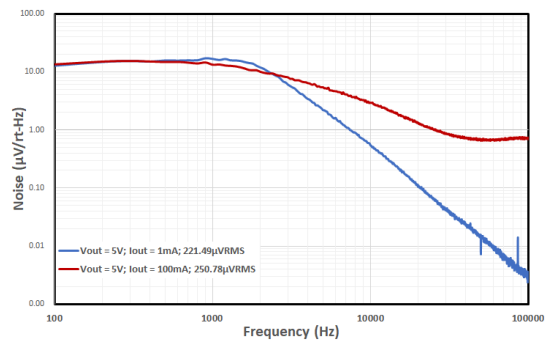

Figure 3-12 Noise VS Frequency

4 Detail Description

4.1 Overview

The SNE2402 is a 40V, 150mA low-dropout (LDO) linear regulator with ultra-low quiescent current. This voltage regulator consumes only 3.5 μ A of quiescent current at light load, and is designed for the automotive always-on application.

4.2 Functional Block Diagram

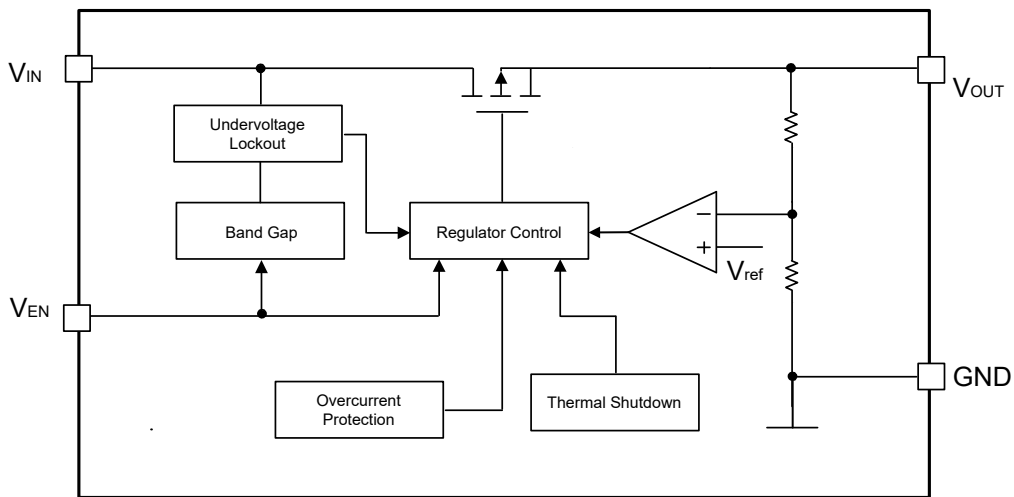

4.3 Feature Description

4.3.1 Device Enable (EN)

The EN pin is a high-voltage-tolerant pin. A high input activates the device and turns the regulation ON. Connect this pin to an external microcontroller or a digital circuit to enable and disable the device, or connect to the IN pin for self-bias applications.

4.3.2 Undervoltage Shutdown

This device has an integrated undervoltage lockout (UVLO) circuit to shut down the output if the input voltage (V_{IN}) falls below an internal UVLO threshold ($V_{(UVLO)}$). This threshold limit ensures that the regulator does not latch into an unknown state during low-input-voltage conditions. If the input voltage has a negative transient that drops below the UVLO threshold and recovers, the regulator shuts down and powers up with a normal power-up sequence when the input voltage is above the required level.

4.3.3 Current Limit

This device features current-limit protection to keep the device in a safe operating area when an overload or output short-to-ground condition occurs. This limit protects the device from excessive power dissipation. For example, during a short-circuit condition on the output, fault protection limits the current through the pass element to $I_{(LIM)}$ to protect the device from excessive power dissipation.

4.3.4 Thermal Shutdown

This device incorporates a thermal shutdown (TSD) circuit as a protection from overheating. For continuous normal operation, the junction temperature must not exceed the TSD trip point. The junction temperature exceeding the TSD trip point causes the output to turn off. When the junction temperature falls below the TSD trip point minus thermal shutdown hysteresis, the output turns on again.

4.4 Device Functional Modes

4.4.1 Operation With V_{IN} Lower Than 3V

The device normally operates with input voltages above 3V. The device can also operate at lower input voltages; the maximum UVLO voltage is 2.85V. At input voltages below the actual UVLO voltage, the device does not operate.

4.4.2 Operation With V_{IN} Larger Than 3V

When V_{IN} is greater than 3 V, if V_{IN} is also higher than the output set value plus the device dropout voltage, V_{OUT} is equal to the set value. Otherwise, V_{OUT} is equal to V_{IN} minus the dropout voltage.

5 Package Outline

5.1 MSOP-8

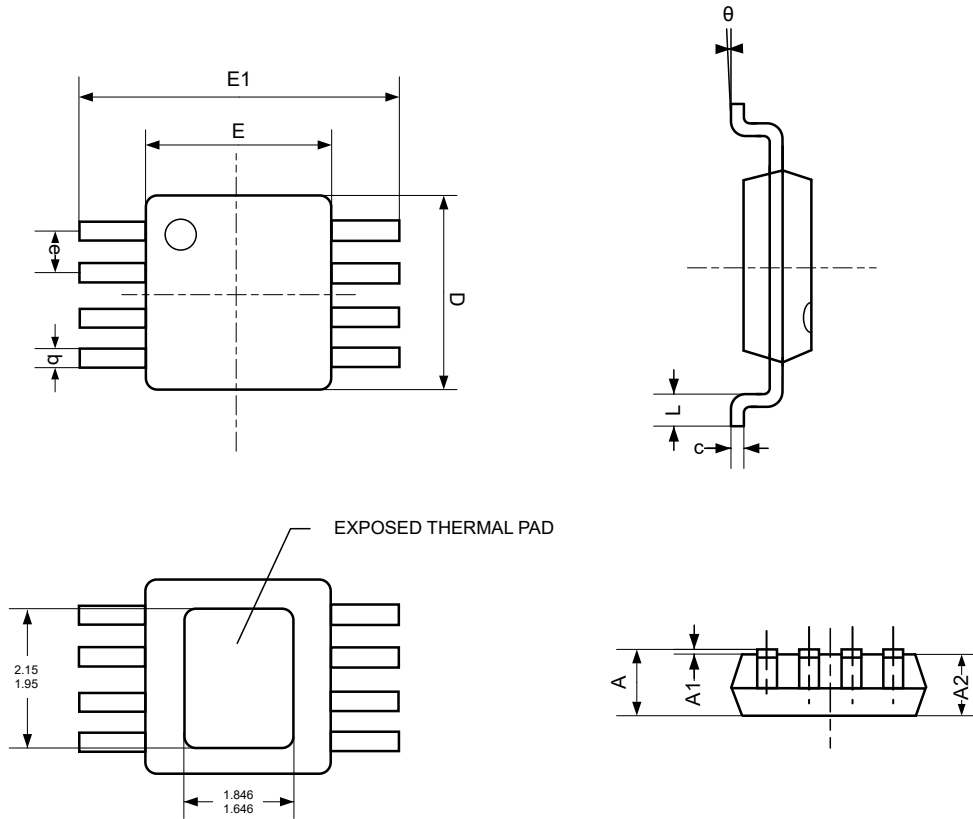

Symbol	Dimensions in Millimeters		Dimensions in Inches	
	Min	Max	Min	Max
A	0.820	1.100	0.032	0.043
A1	0.020	0.150	0.001	0.006
A2	0.750	0.950	0.030	0.037
b	0.250	0.380	0.010	0.015
c	0.090	0.230	0.004	0.009
D	2.900	3.100	0.114	0.122
E	2.900	3.100	0.114	0.122
E1	4.750	5.050	0.187	0.199
e	0.650 BSC		0.026 BSC	
L	0.400	0.800	0.016	0.031
θ	0°	6°	0°	6°

5.2 DFN-6

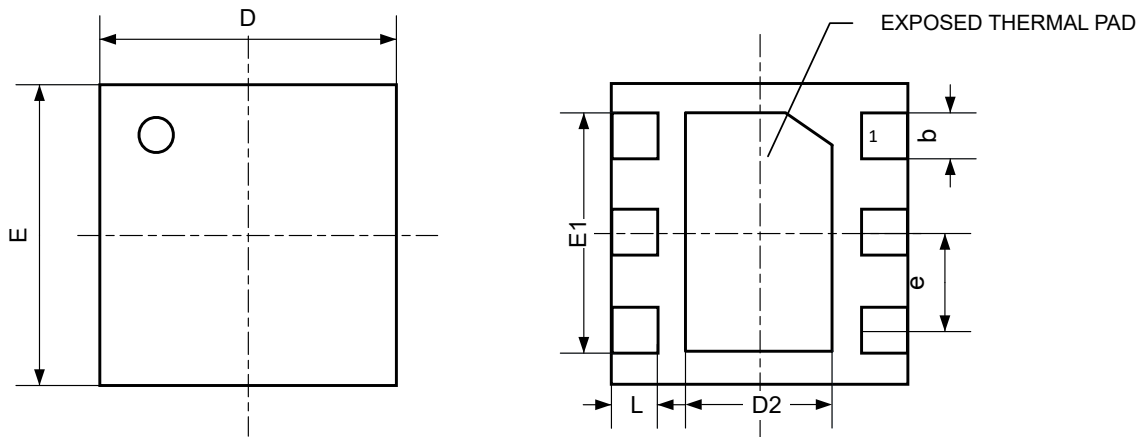

TOP VIEW

BOTTOM VIEW

SIDE VIEW

Symbol	Dimensions in Millimeters		Dimensions in Inches	
	Min	Max	Min	Max
A	0.700	0.800	0.028	0.031
A1	0.000	0.050	0.000	0.002
A2	0.500	0.600	0.020	0.024
b	0.250	0.350	0.001	0.014
D2	0.900	1.100	0.035	0.043
D	1.900	2.100	0.075	0.083
E	1.900	2.100	0.075	0.083
E1	1.500	1.700	0.059	0.067
e	0.650 BSC		0.026 BSC	
L	0.200	0.300	0.008	0.0012

5.3 TO-252-5

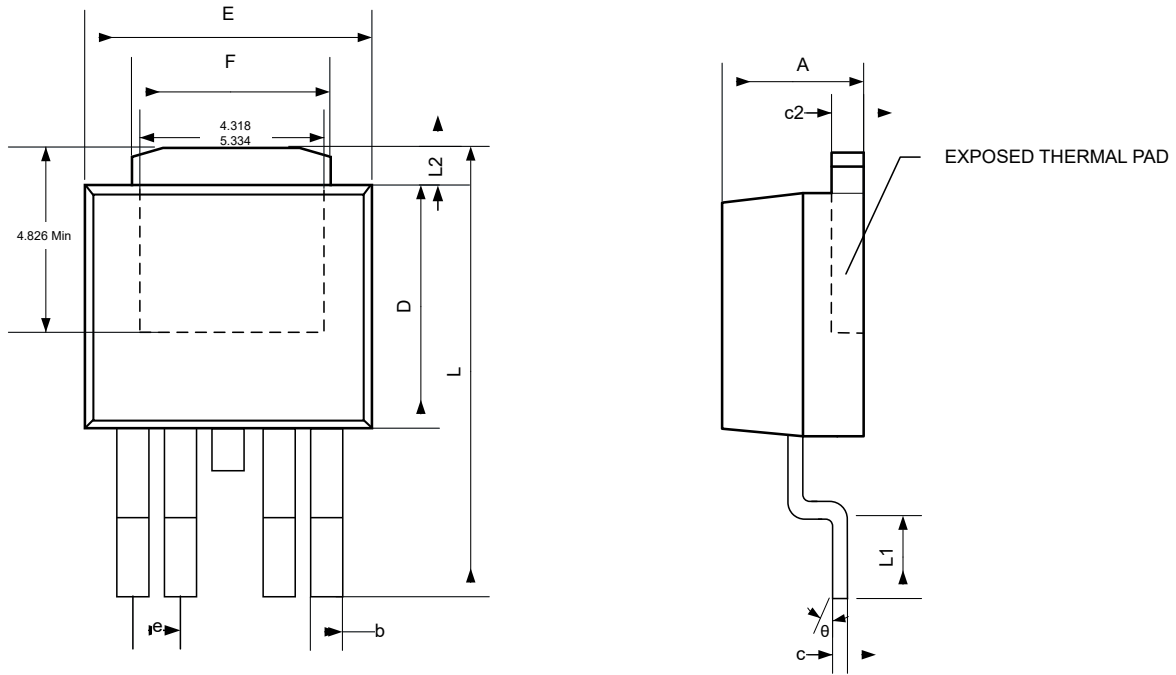

Symbol	Dimensions in Millimeters		Dimensions in Inches	
	Min	Max	Min	Max
A	2.18	2.39	0.086	0.094
c2	0.46	0.61	0.018	0.024
L1	1.40	1.78	0.055	0.070
b	0.51	0.71	0.020	0.028
L2	0.89	1.27	0.035	0.050
D	5.97	6.22	0.235	0.245
L	9.80	10.41	0.386	0.410
E	6.50	6.70	0.256	0.264
F	4.32	5.46	0.170	0.215
e	1.14 BSC		0.045 BSC	
c	0.51 TYP		0.020 TYP	
θ	0°	8°	0°	8°

5.4 SOT223-4

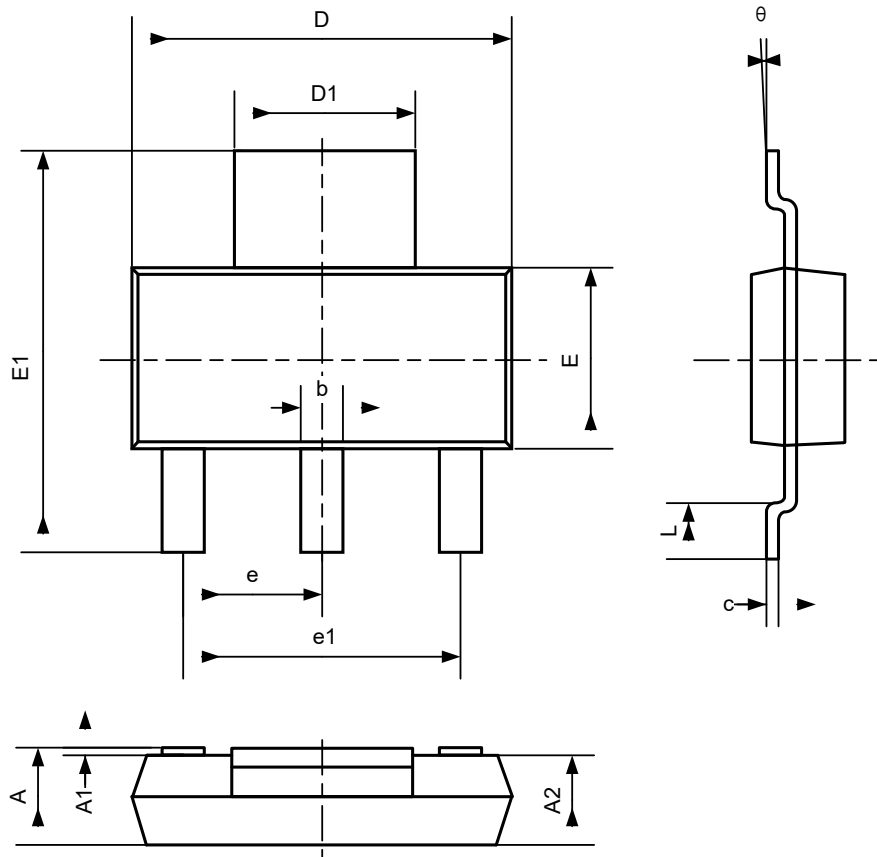

Symbol	Dimensions in Millimeters		Dimensions in Inches	
	Min	Max	Min	Max
A	1.520	1.800	0.060	0.071
A1	0.000	0.100	0.000	0.004
A2	1.500	1.700	0.059	0.067
b	0.660	0.820	0.026	0.032
c	0.250	0.350	0.010	0.014
D	6.200	6.400	0.244	0.252
D1	2.900	3.100	0.114	0.122
E	3.300	3.700	0.130	0.146
E1	6.830	7.070	0.269	0.278
e	2.300 BSC		0.091 BSC	
e1	4.500	4.700	0.177	0.185
L	0.900	1.150	0.035	0.045
θ	0°	10°	0°	10°

5.5 DFN-8(3mmx3mm)

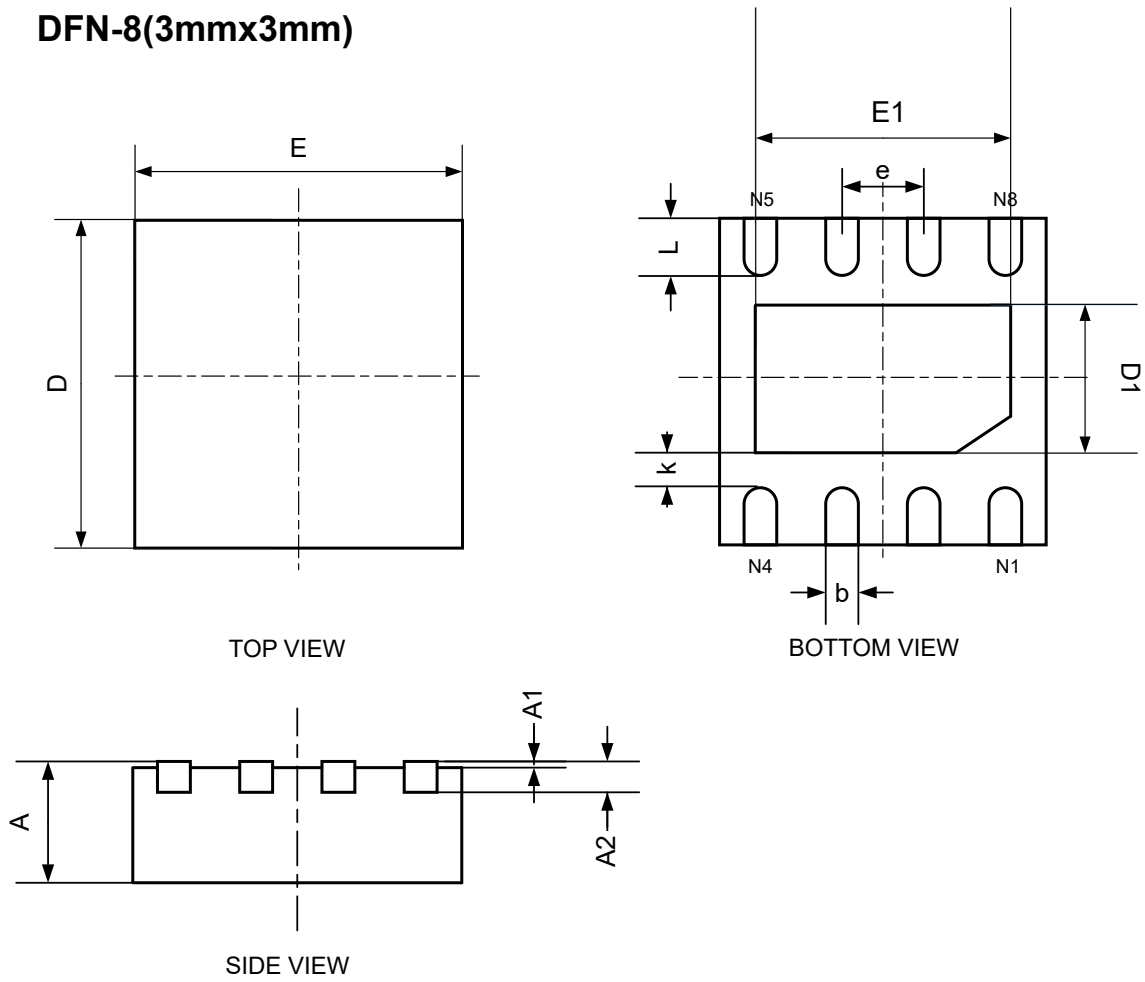

Symbol	Dimensions in Millimeters			Dimensions in Inches		
	Min	Nom	Max	Min	Nom	Max
A	0.800	0.900	1.000	0.031	0.035	0.039
A1	0.000	0.020	0.050	0.000	0.001	0.002
A2	0.200 REF			0.008 REF		
b	0.250	0.300	0.350	0.010	0.012	0.014
D	2.900	3.000	3.100	0.114	0.118	0.122
E	2.900	3.000	3.100	0.114	0.118	0.122
D1	1.550	1.650	1.750	0.061	0.065	0.069
E1	2.250	2.400	2.550	0.089	0.094	0.100
e	0.650 BSC			0.026 BSC		
k	0.280 REF			0.011 REF		
L	0.300	0.400	0.500	0.012	0.016	0.020

5.6 SOT23-5

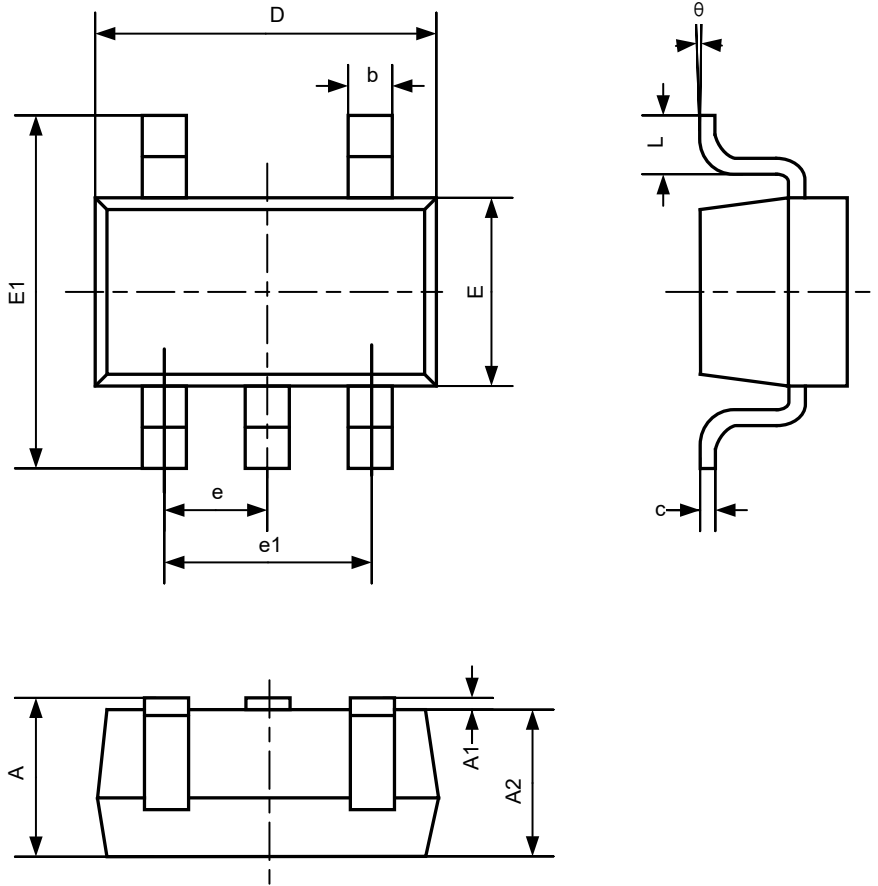

Symbol	Dimensions in Millimeters		Dimensions in Inches	
	Min	Max	Min	Max
A	1.050	1.250	0.041	0.049
A1	0.000	0.100	0.000	0.004
A2	1.050	1.150	0.041	0.045
b	0.300	0.500	0.012	0.020
c	0.100	0.200	0.004	0.008
D	2.820	3.020	0.111	0.119
E	1.500	1.700	0.059	0.067
E1	2.650	2.950	0.104	0.116
e	0.950 BSC		0.037 BSC	
e1	1.900 BSC		0.075 BSC	
L	0.300	0.600	0.012	0.024
θ	0°	8°	0°	8°

6 Revision History

Version	Date	Description
0.1	2022/08/26	Initial release
0.2	2023/03/10	Add Package: SOT223-4,DFN-8,SOT-23-5
1.0	2023/09/21	Official version

Copyright and Important Notice

No part of this document shall be excerpted, translated, reproduced, transmitted, or disseminated by any organization, company, or individual in any form or by any means without the prior written consent of Nanjing Senasic Electronic Technology Co.,Ltd.

 捷 and other SENASIC icons are trademarks of Nanjing Senasic Electronic Technology Co.,Ltd.(former Ningbo SENASIC Electronic Technology Co., Ltd.abbreviated as SENASIC).

The purchased products, services and features are stipulated by the contract made between SENASIC and the customer. All or part of the products, services and features described in this document may not be within the purchase scope or the usage scope. Unless otherwise specified in the contract, all statements, information, and recommendations in this document are provided "AS IS" without warranties, guarantees or representations of any kind, either express or implied.

The content of this document may be changed due to product version upgrades, adjustments, or other reasons.Unless otherwise agreed, this document is used as Use guide only, all statements, information, and recommendations in this document do not constitute a warranty of any kind, express or implied.

For further information on technical support, delivery and prices, please call the national consultation hotline: [021-5061-0206](tel:021-5061-0206), or you can obtain relevant support by email info@senasic.com.

Copyright © 2023 Nanjing Senasic Electronic Technology Co.,Ltd. All rights reserved.